

# OFFCUT

WALL SCENCE

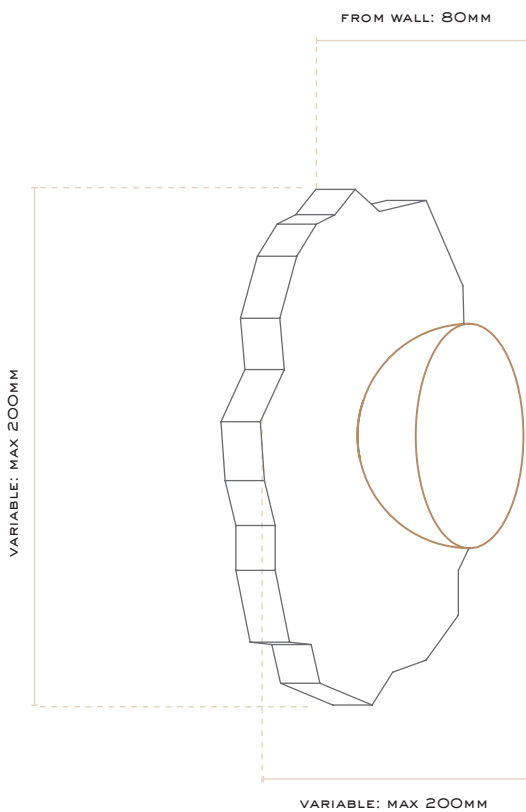



## OFFCUT WALL SCONCE



### COLOURS:

Glass: Frosted White

Stone options:

Limestone, Arabescato, Mojito  
plus limited edition stones

Each stone is hand selected, images are indicative  
of the finished product, the shape and colour of  
the selected stone is unique for every piece.

### COLOUR TEMPERATURE

Warm White 3000K



### LIGHT FITTING:

WATTAGE:

5W, 550mA Constant Current

IP RATING:

IP20

REMOTE DRIVER (INCLUDED):

TCI Mini Jolly (size: 102mm x 38mm x 21mm)

Allow room in wall cavity or a distance up to 100mm from fitting

DIMMING OPTIONS:

1-10V, Non-dim, Push

All fixtures must be installed by a licensed electrician. Please also consult a licensed electrician for any electrical, dimming and wiring enquiries.



## OFFCUT WALL SCONCE (IP20)

### *Installation guide*

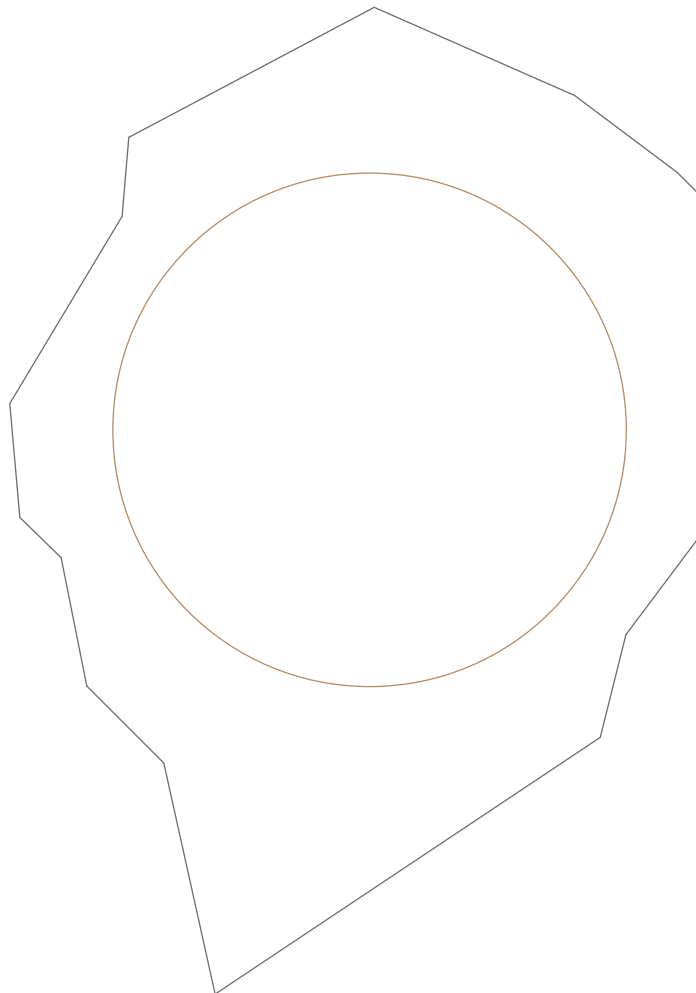

*LOW VOLTAGE - Do not wire light fitting directly to mains power.*

# OFFCUT WALL SCONCE

## Installation guide



**DANGER** electric shock risk. Installation must be conducted by a licensed electrician.

### STAGE 1: INSTALL DRIVER

#### TCI Mini Jolly 125400

550mA Constant Current

Minimum cut-out hole diameter: 55 mm

Size: 111 x 22 x 52 mm

Plastic case: IP20 rated

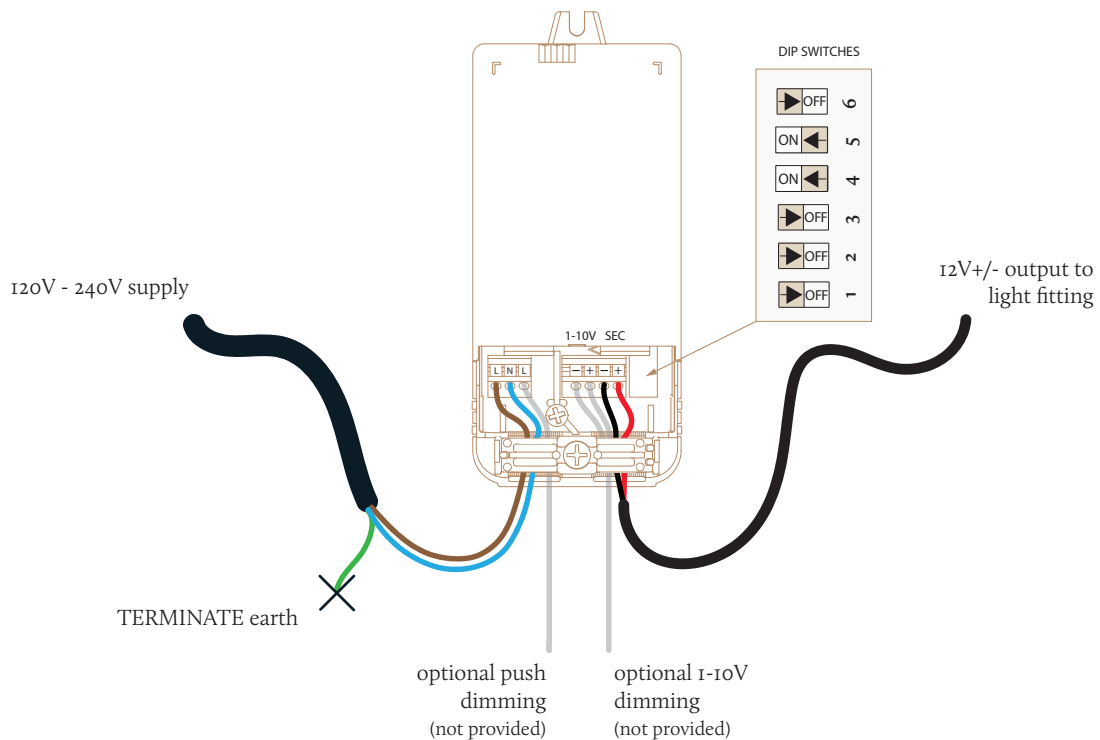

- 1: Select driver location, ideally a remote location that is accessible such as an attic or cupboard. Affix driver to solid surface.
- 2: Unscrew terminal cover and unclick from sides.
- 3: Check DIP switches are set to required position - if not, set to pattern as shown above using a small screwdriver.
- 4: Ensure mains supply is switched off. Connect 120V-240V Load and Neutral supply to the left side of the driver as shown.
- 5: Terminate earth if present.
- 6: *Option A:* While at the framing stage, run a 2x core cable from the SEC output on the driver, to the desired position of the luminaire.  
*Option B:* If the driver must be located behind the luminaire. Connect +/- from LED luminaire to right side of driver in the SEC output.
- 7: (*Optional, not supplied*) If dimming is required, connect leads for 1-10V or Push Dimmer as illustrated.
- 8: Reattach terminal cover and screw closed.

## STAGE 2: INSTALL FITTING

 Ensure gloves are worn when handling natural brass products.



**LOW VOLTAGE** - Do not wire light fitting directly to mains power.

### STEP 1:

- Remove all items from box. **Carefully handle the stone as it may have sharp edges.**
- Install driver as shown on opposite page.
- Unscrew glass from brass dome LED module and carefully place aside.
- Using HEX key provided, loosen M6 grub screw on LED module.

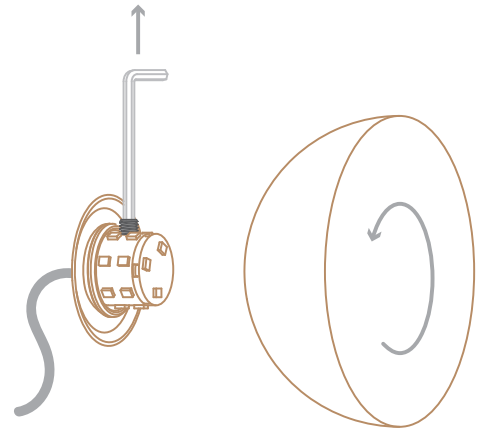

### STEP 2:

- Thread white cable power supply through the stone and through the black wall bracket.
- Have someone else hold the LED module, stone and wall bracket.

(Alternately place these items on a stool or something of a similar height.)

- Trim cables as necessary and connect +/- power supply from LED luminaire to TCI Mini Jolly driver using wago connectors.

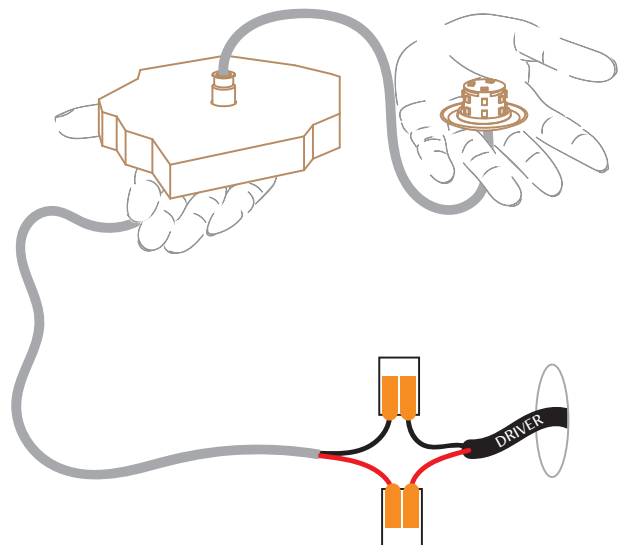

**DO NOT HANG THE STONE ON THE CABLE**



### STEP 3:

- Install bracket to wall using timber screws provided.
- Pass the surplus cable into the wall cavity.



## STAGE 2: INSTALL FITTING CONTINUED

### STEP 4:

- Carefully place stone and LED module onto the stem of the black wall bracket.
- Apply pressure on the stone, tighten M6 grub screw to fix the LED module in place.
- Check fitting is secure before proceeding.

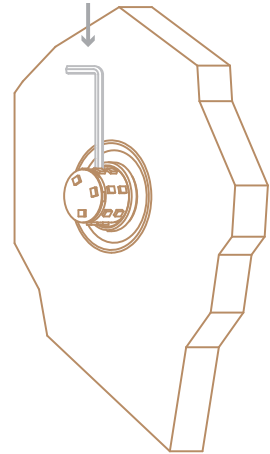

### STEP 5:

- Carefully screw glass diffuser onto module.

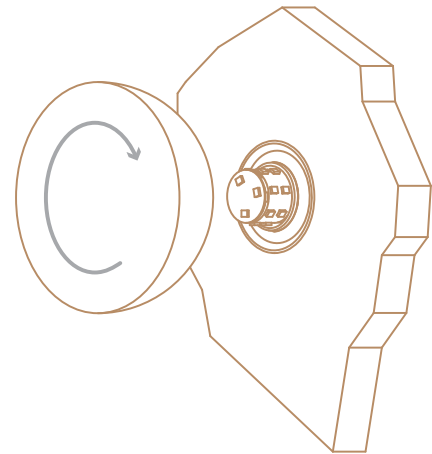

### STEP 6:

- Wipe down fitting with supplied dry cloth.
- Test fitting.

